

**CMPT3019**  
**NPN SILICON TRANSISTOR**

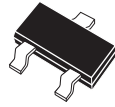

**SOT-23 CASE**

# Central<sup>TM</sup>

**Semiconductor Corp.**

**DESCRIPTION:**

The CENTRAL SEMICONDUCTOR CMPT3019 type is an NPN silicon transistor manufactured by the epitaxial planar process, epoxy molded in a surface mount package, designed for very high current, general purpose amplifier applications.

**MARKING CODE: C3A**

**MAXIMUM RATINGS:** ( $T_A=25^\circ\text{C}$ )

	SYMBOL		UNITS
Collector-Base Voltage	$V_{CBO}$	120	V
Collector-Emitter Voltage	$V_{CEO}$	80	V
Emitter-Base Voltage	$V_{EBO}$	7.0	V
Continuous Collector Current	$I_C$	500	mA
Peak Collector Current	$I_{CM}$	1.0	A
Power Dissipation	$P_D$	350	mW
Operating and Storage			
Junction Temperature	$T_J, T_{stg}$	-65 to +150	$^\circ\text{C}$
Thermal Resistance	$\theta_{JA}$	357	$^\circ\text{C/W}$

**ELECTRICAL CHARACTERISTICS:** ( $T_A=25^\circ\text{C}$  unless otherwise noted)

SYMBOL	TEST CONDITIONS	MIN	MAX	UNITS
$I_{CBO}$	$V_{CB}=90\text{V}$		10	nA
$I_{EBO}$	$V_{EB}=5.0\text{V}$		10	nA
$BV_{CBO}$	$I_C=100\mu\text{A}$	120		V
$BV_{CEO}$	$I_C=30\text{mA}$	80		V
$BV_{EBO}$	$I_E=100\mu\text{A}$	7.0		V
$V_{CE(SAT)}$	$I_C=150\text{mA}, I_B=15\text{mA}$		0.2	V
$V_{CE(SAT)}$	$I_C=500\text{mA}, I_B=50\text{mA}$		0.5	V
$V_{BE(SAT)}$	$I_C=150\text{mA}, I_B=15\text{mA}$		1.1	V
$h_{FE}$	$V_{CE}=10\text{V}, I_C=0.1\text{mA}$	50		
$h_{FE}$	$V_{CE}=10\text{V}, I_C=10\text{mA}$	90		
$h_{FE}$	$V_{CE}=10\text{V}, I_C=150\text{mA}$	100	300	
$h_{FE}$	$V_{CE}=10\text{V}, I_C=500\text{mA}$	50		
$f_T$	$V_{CE}=10\text{V}, I_C=50\text{mA}, f=1.0\text{MHz}$	100		MHz
$C_{ob}$	$V_{CB}=10\text{V}, I_E=0, f=1.0\text{MHz}$		12	pF
$C_{ib}$	$V_{EB}=0.5\text{V}, I_C=0, f=1.0\text{MHz}$		60	pF
NF	$V_{CE}=10\text{V}, I_C=100\text{mA}, R_S=1\text{k}\Omega, f=1.0\text{kHz}$		4.0	dB

R2 (13-November 2002)

SOT-23 CASE - MECHANICAL OUTLINE

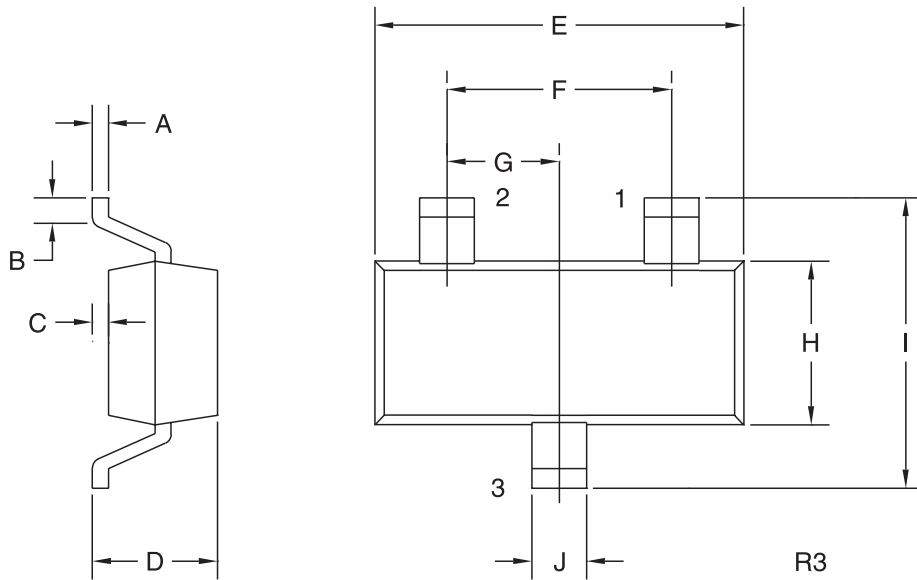

**LEAD CODE:**

- 1) BASE
- 2) EMITTER
- 3) COLLECTOR

**MARKING CODE: C3A**

SYMBOL	DIMENSIONS			
	INCHES		MILLIMETERS	
	MIN	MAX	MIN	MAX
A	0.003	0.007	0.08	0.18
B	0.006	-	0.15	-
C	-	0.005	-	0.13
D	0.035	0.043	0.89	1.09
E	0.110	0.120	2.80	3.05
F	0.075		1.90	
G	0.037		0.95	
H	0.047	0.055	1.19	1.40
I	0.083	0.098	2.10	2.49
J	0.014	0.020	0.35	0.50

SOT-23 (REV: R3)